

Service Manual

AVR100

Issue 2.0

DiVA AVR100 Surround Sound Receiver



ARCAM

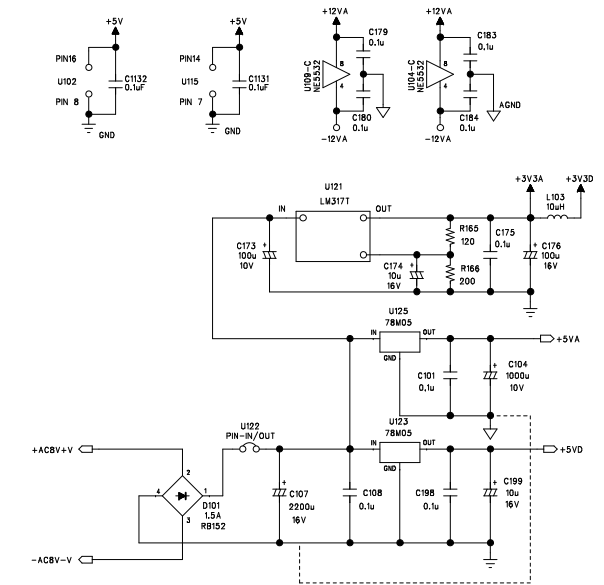
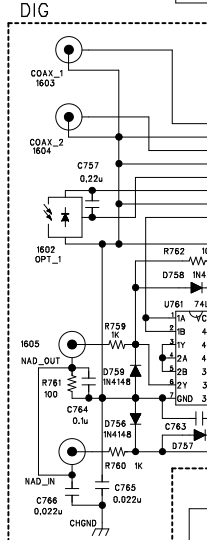
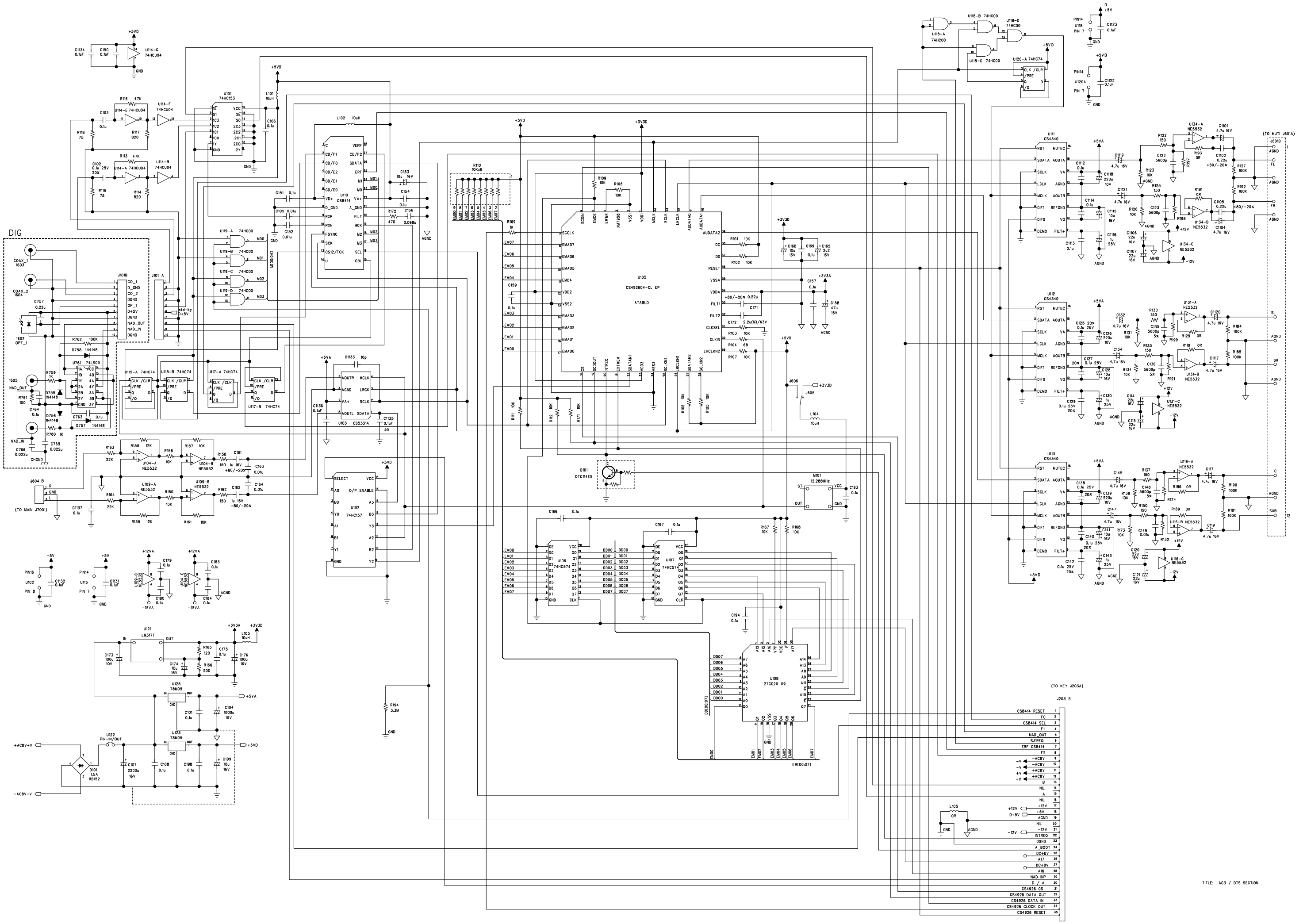

J203 B

1	CS8414 RESET
2	FG
3	CS8414 SEL
4	F1
5	NAD_OUT
6	S.FREQ
7	ERF CS8414
8	F2
9	-ACBV
10	-ACBV
11	-ACBV
12	+ACBV
13	+ACBV
14	B
15	NL
16	A
17	NL
18	+12V
19	+5V
20	AGND
21	NL
22	-12V
23	INTREQ
24	DGND
25	A_B00T
26	DC+BV
27	A17
28	DC+BV
29	NAD_INP
30	D / A
31	CS4926 CS
32	CS4926 DATA OUT
33	CS4926 DATA IN
34	CS4926 CLOCK OUT
35	CS4926 RESET

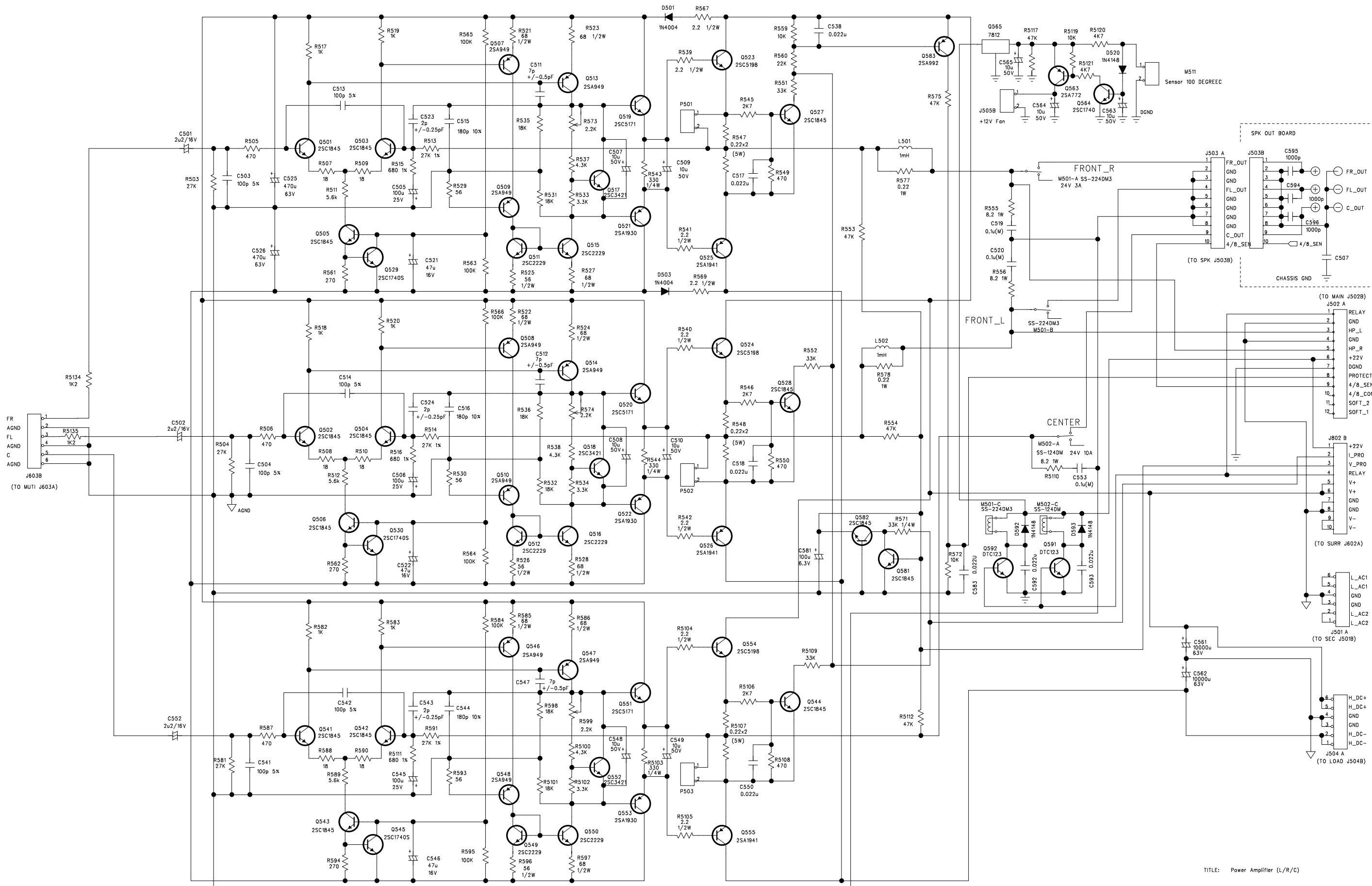

TITLE: Power Amplifier (L/R/C)

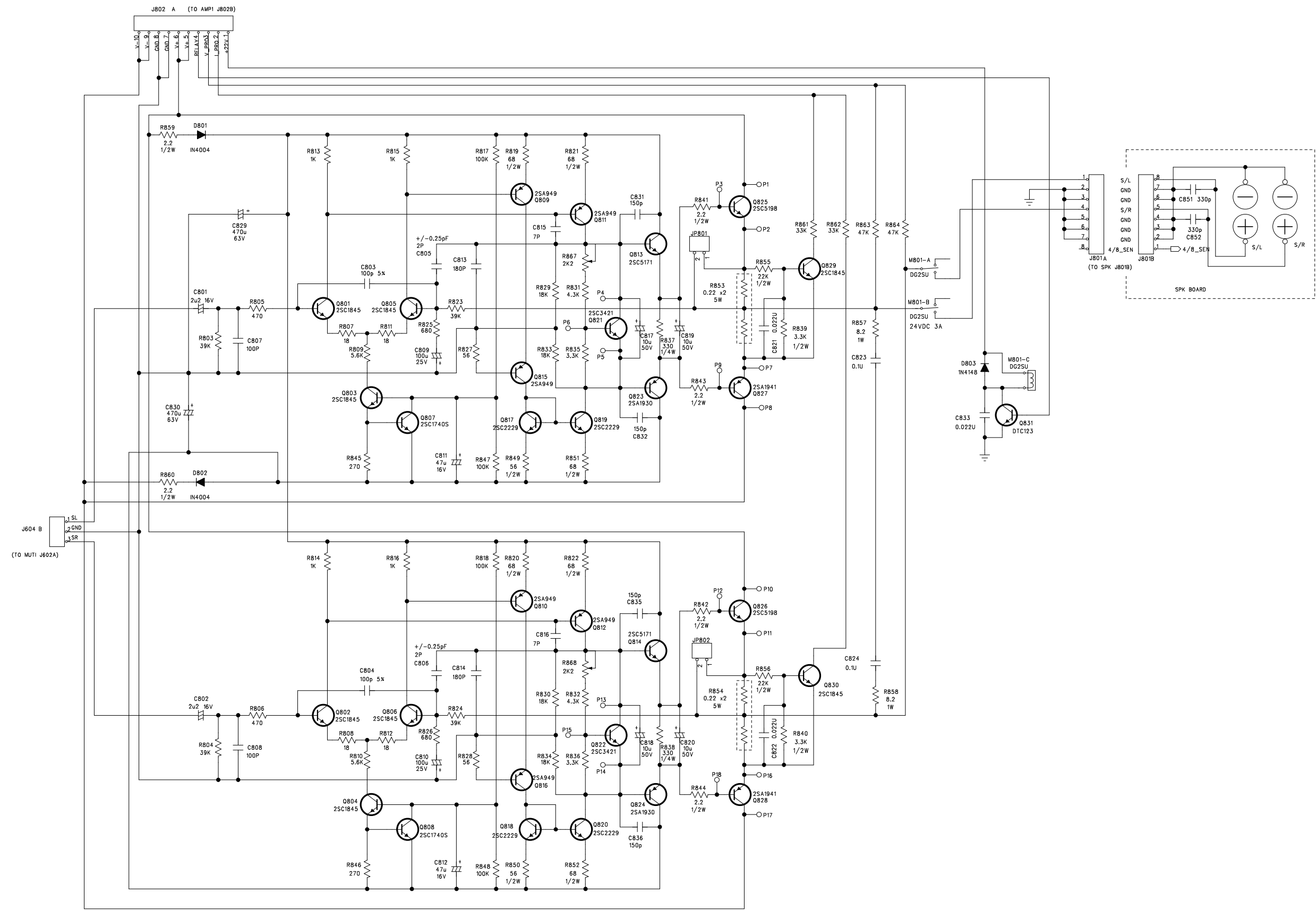

TITLE: Rear Amplifier / AMP2

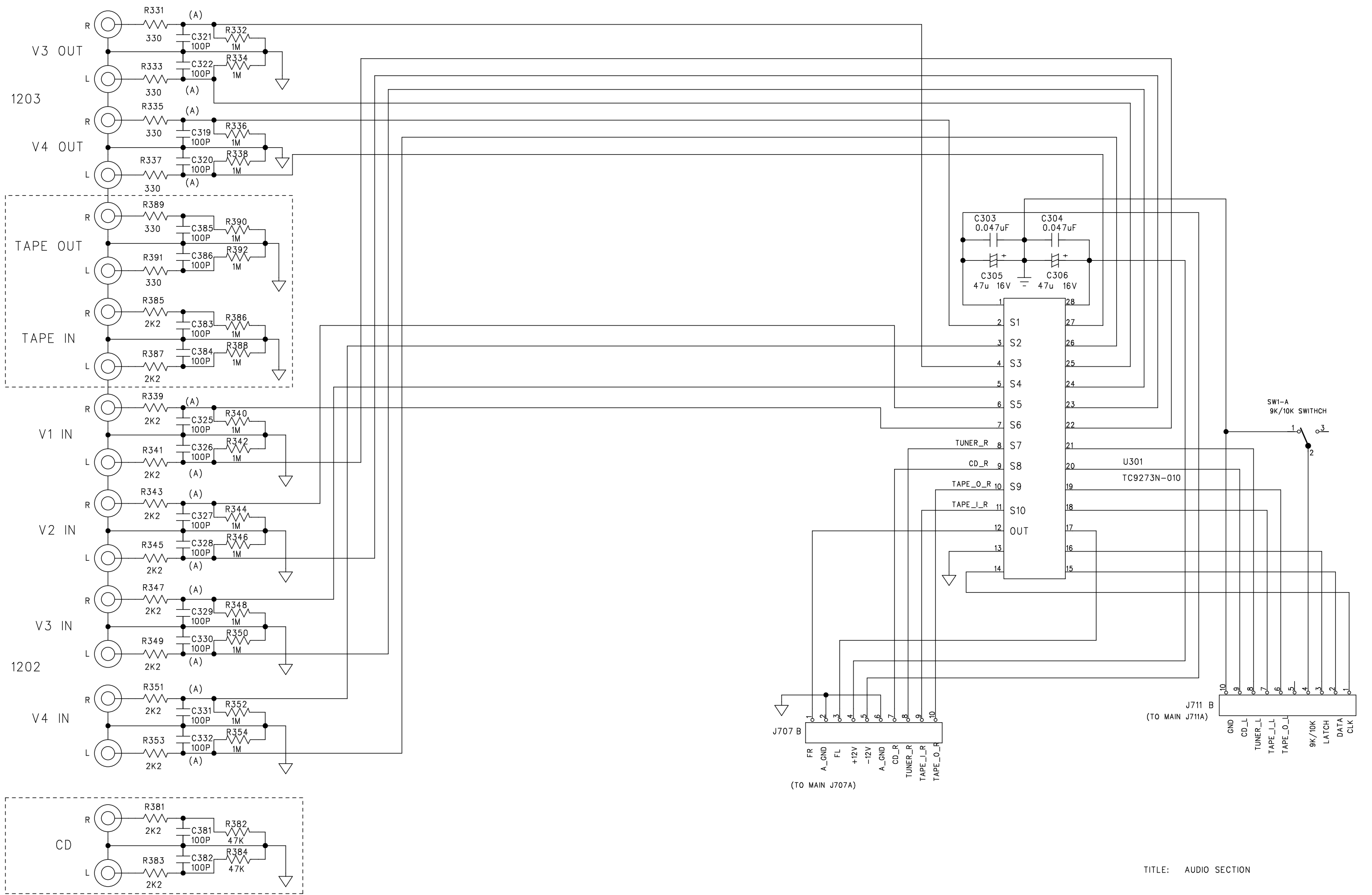

TITLE: AUDIO SECTION

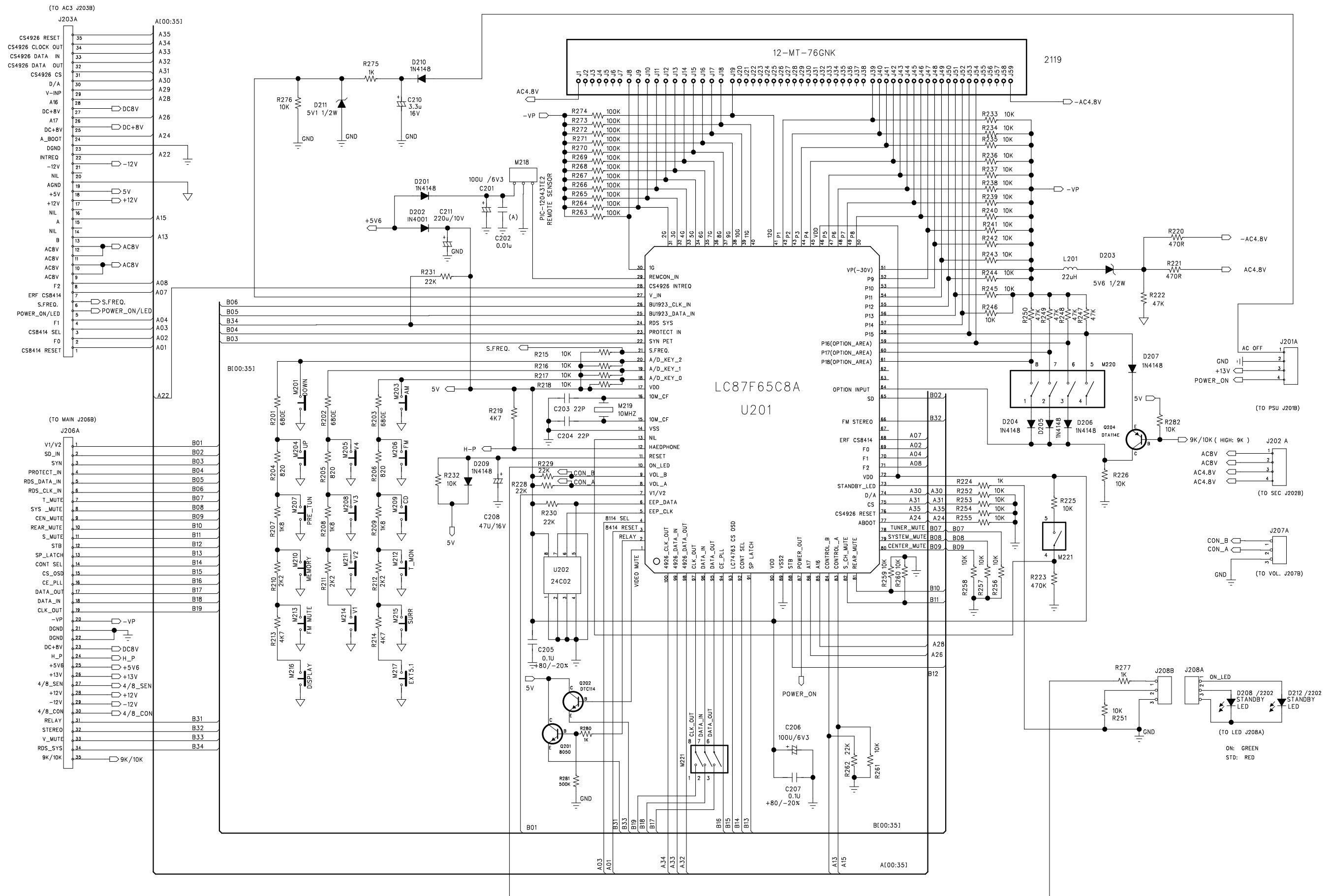

TITLE: KEYBOARD / DISPLAY BOARD

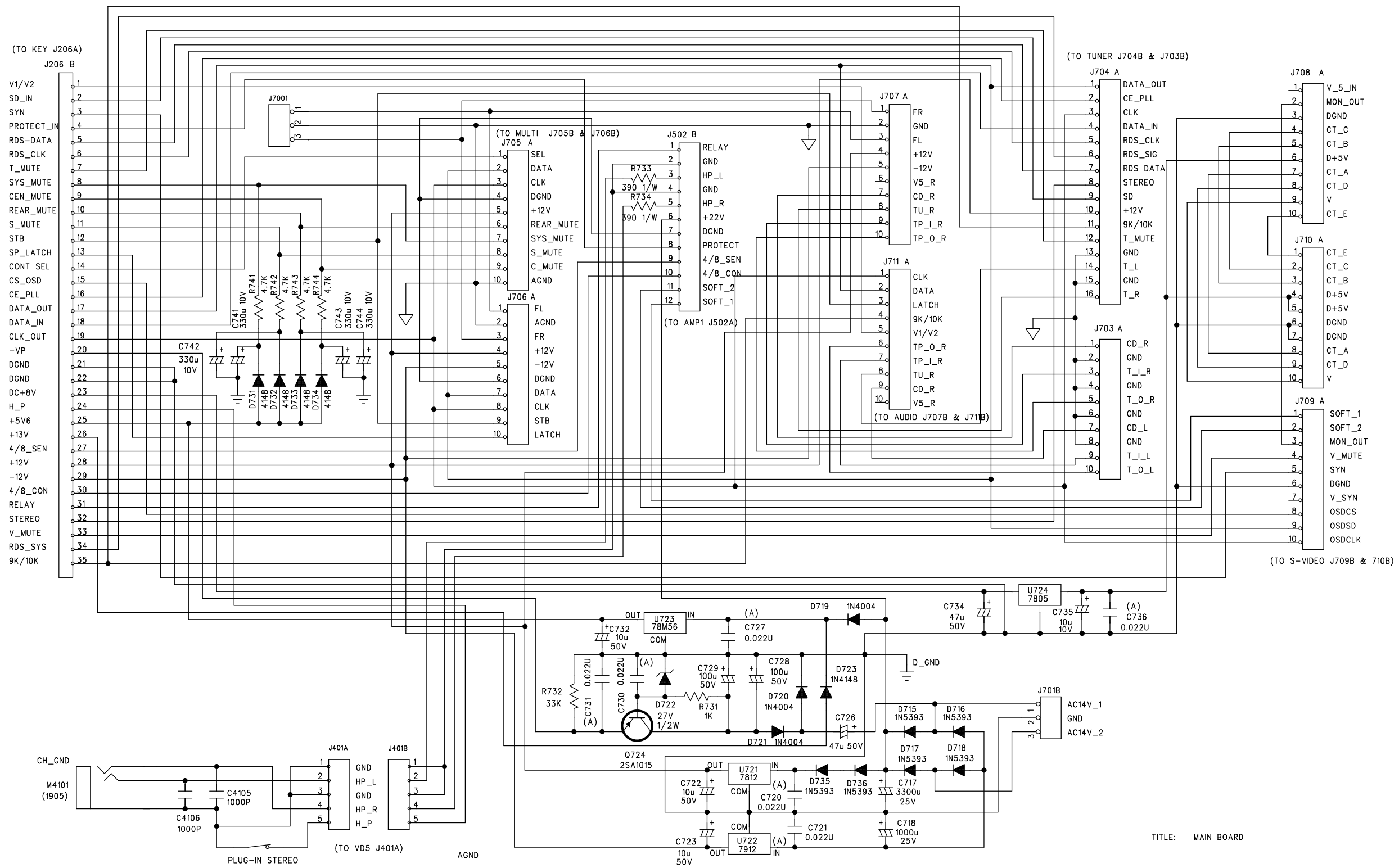

TITLE: MAIN BOARD

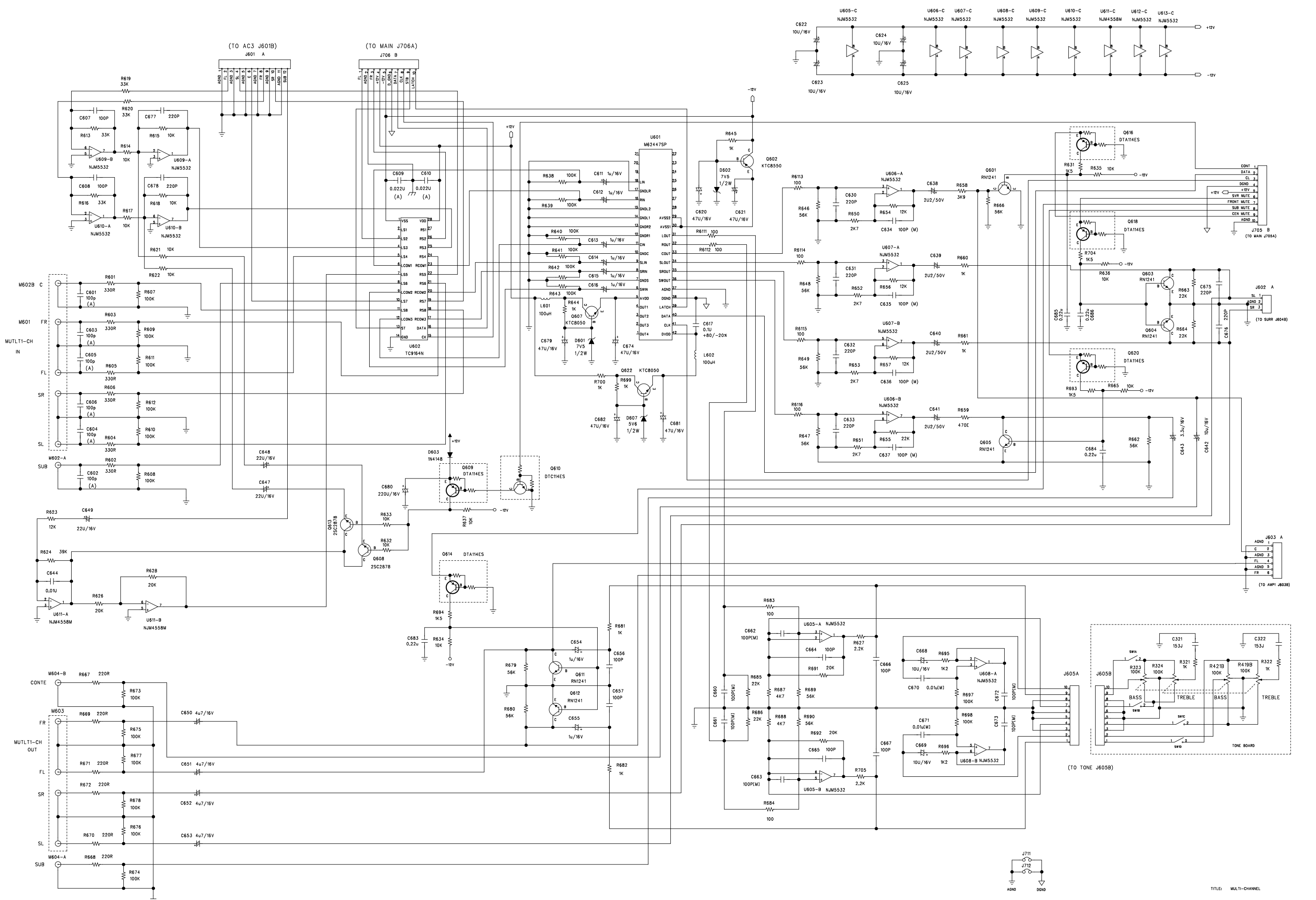

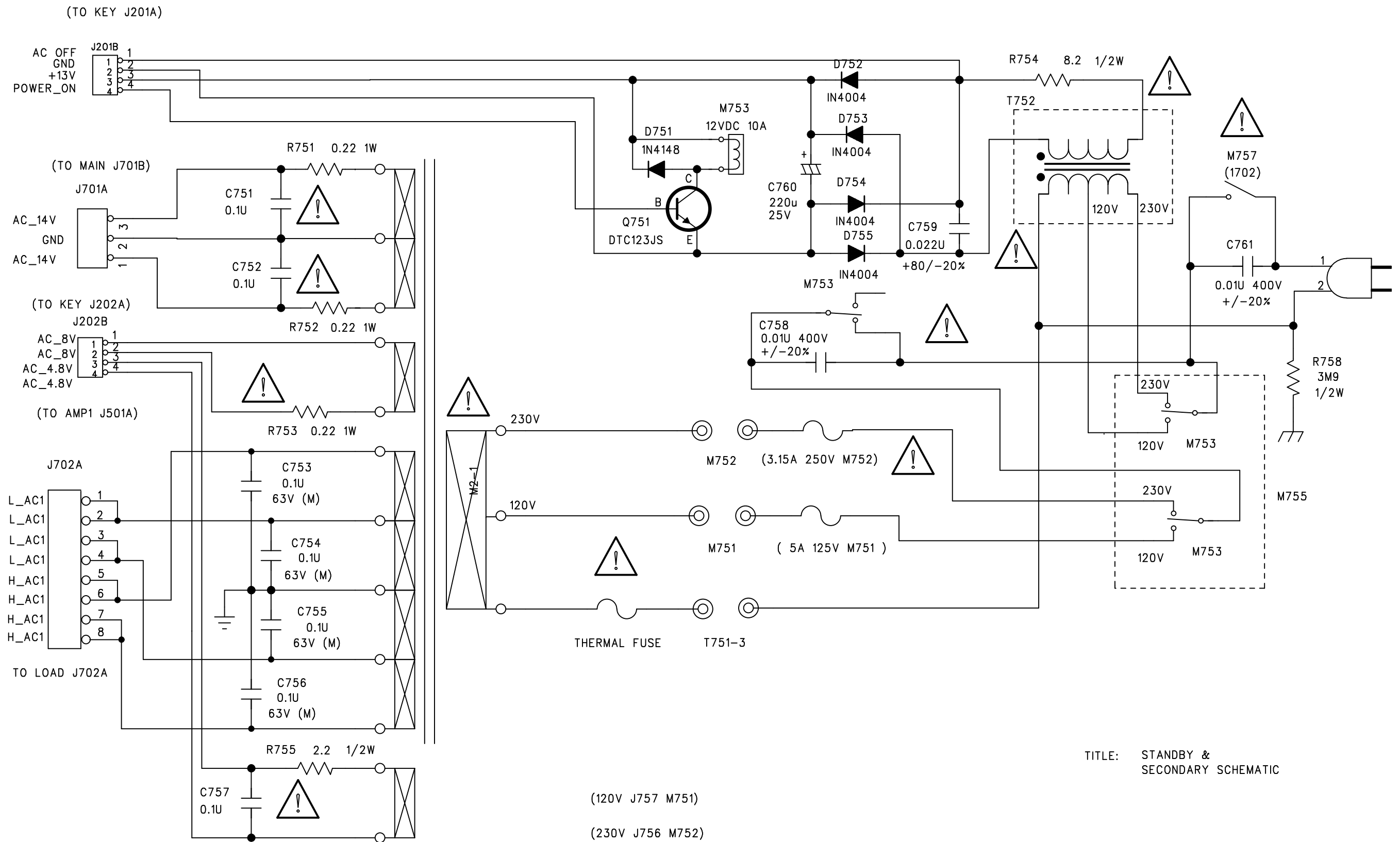

TITLE: STANDBY & SECONDARY SCHEMATIC

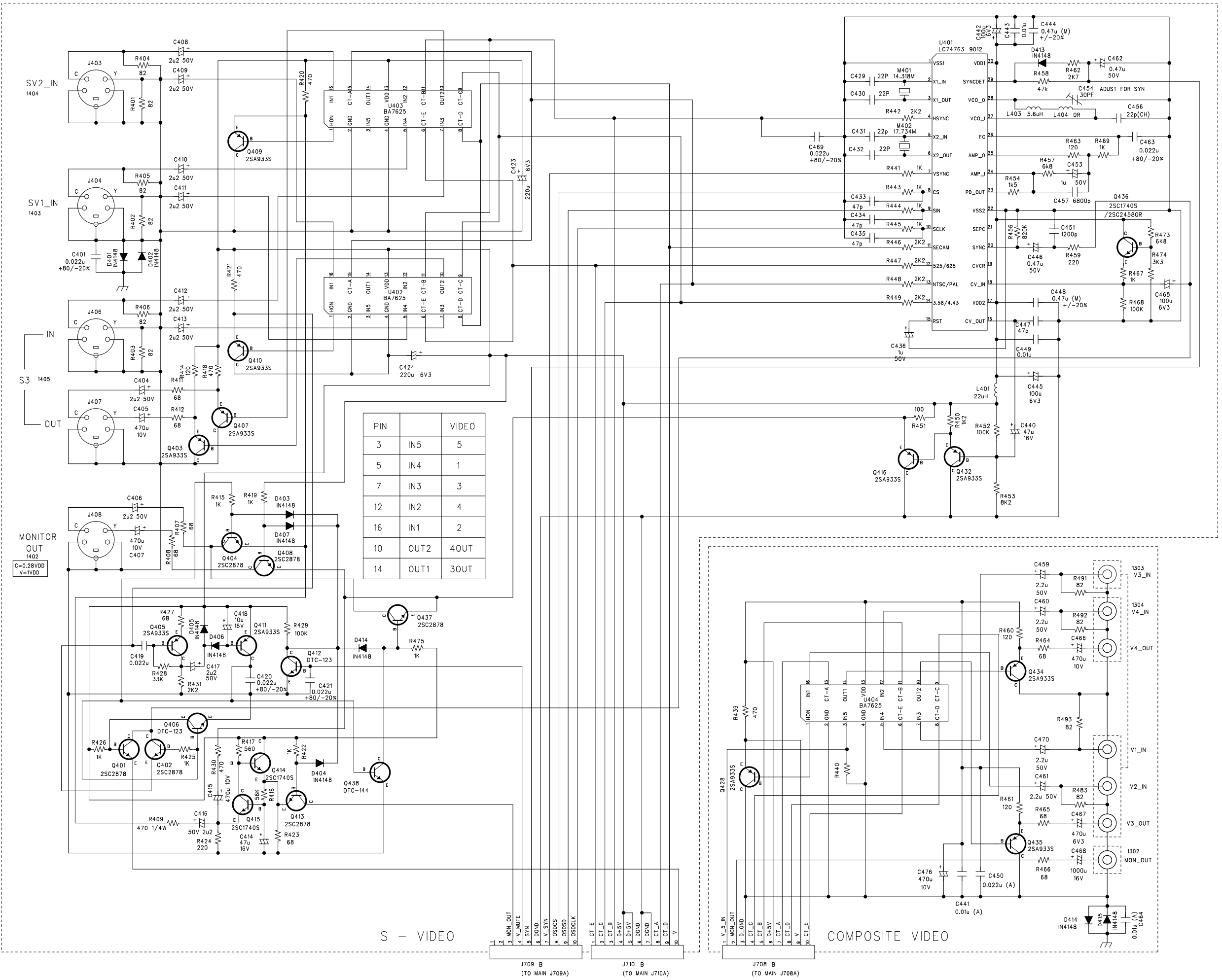

PIN	VIDEO
3	IN5 5
5	IN4 1
7	IN3 3
12	IN2 4
16	IN1 2
10	OUT2 4OUT
14	OUT1 3OUT

S - VIDEO

COMPOSITE VIDEO

J709 B
(TO MAIN J709A)

J710 B
(TO MAIN J710A)

J708 B
(TO MAIN J708A)

TITLE: VIDEO BOARD (S-VIDEO / VIDEO)

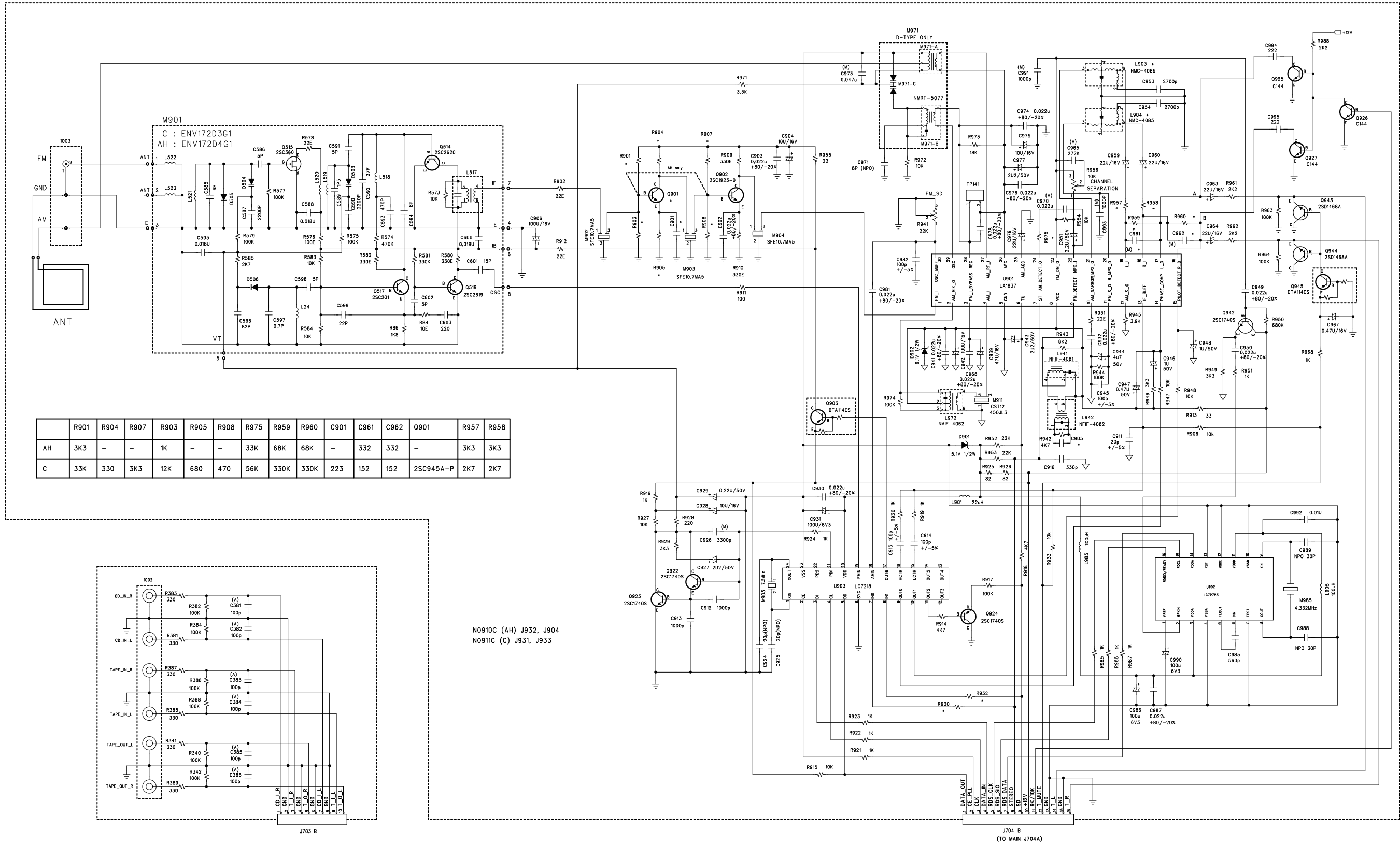

	R901	R904	R907	R903	R905	R908	R975	R959	R960	C901	C961	C962	Q901	R957	R958
AH	3K3	-	-	1K	-	-	33K	68K	68K	-	332	332	-	3K3	3K3
C	33K	330	3K3	12K	680	470	56K	330K	330K	223	152	152	2SC945A-P	2K7	2K7

N0910C (AH) J932, J904
 N0911C (C) J931, J933

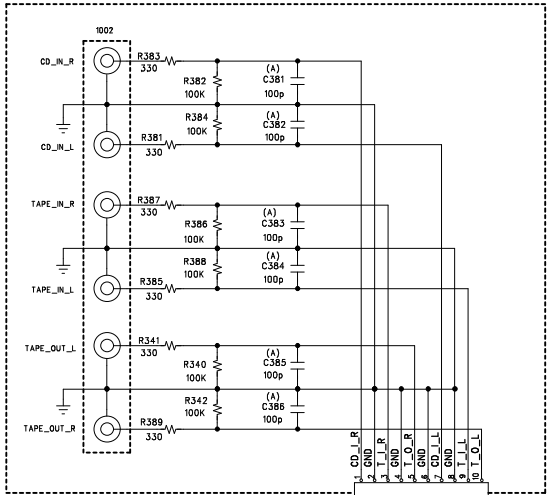

J703 B

J704 B
(TO MAIN J704A)

AVR100 Spares List

Arcam Part Number	Description
TGP001	AVR100 IC CS5331A 18BIT A/D
TGP002	AVR100 IC CS4926 DSP CRYSTAL
TGP003	AVR100 IC CS8414 DIR 96KHZ
TGP004	AVR100 IC CS4340 D/A CONVERTER
TGP005	AVR100 IC CS5331A 18BIT A/D
TGP006	AVR100 IC 74HC153 QUAD 4-INPUT
TGP007	AVR100 IC 74HC 157 QUAD 2-INPUT
TGP008	AVR100 IC 74HC574 8X D-TYPE
TGP009	AVR100 IC74HCU04 HEX INVERTERS
TGP010	AVR100 IC 74HC74 DUAL D TYPE
TGP011	AVR100 IC 74HC00 QUAD 21/P NAND
TGP012	AVR100 BRIDGE RECTIFIER RB152
TGP013	AVR100 X'TAL 12.288 MHX +/- 20PPM
TGP014	AVR100 TR DTC 114ES
TGP015	AVR100 IC AT27C020-70 256KX8
TGP016	AVR100 SEE ARCAM PART 5A5532
TGP017	AVR100 DIODE BRIDGE RS804M
TGP018	AVR100 RELAY 24 VDC, 125VA, 3A
TGP019	AVR100 RELAY 24 VDC, 250VA, 10A
TGP020	AVR100 THERMOSTOR 100C
TGP021	AVR100 TR 2SC 1845 9f.e.0 RL
TGP022	AVR100 TR 2SA949-0 HFE 70-140
TGP023	AVR100 TR 2SC2229-0 HFE 70-140
TGP024	AVR100 TR 2SC3421 (0, Y) RL TSB
TGP025	AVR100 TR 2SC5171 HFE 100-320
TGP026	AVR100 TR 2SA1930 HFE 100-320
TGP027	AVR100 TR 2SC5198 HFE 80-160
TGP028	AVR100 TR 2SA1941 HFE 80-160
TGP029	AVR100 TR 2SB772P PNP POWER TR
TGP030	AVR100 SEE ARCAM PART 5D7812 IC VREG POS 7812
TGP031	AVR100 SOCKET (PCB/PCB) 10P
TGP032	AVR100 DPDT SLIDE 9for am step)
TGP033	AVR100 ic tc9273n-004 analog
TGP034	AVR100 VFD 12-MT-79GNK FUTBA
TGP035	AVR100 FLEXIBLE CONN 35P
TGP036	AVR100 IE SENSOR PIC 12043TE2
TGP037	AVR100 CRYSTAL 10MHZ +/- 30PPM
TGP038	AVR100 TR SS8050 C/D SAMSUNG RL
TGP039	AVR100 TR DTC 114ES ROHM
TGP040	AVR100 TR DTA 114ESA ROHM
TGP041	AVR100 IC LC87F65C8A 8-BIT MCU
TGP042	AVR100 IC EEPROM 24C02 2KBIT
TGP043	AVR100 DIODE 1N5393 200v 1.5v
TGP044	AVR100 DIODE 1N4004 AL
TGP045	AVR100 DZ 1/2W 27V (26.2-27.6)AT
TGP046	AVR100 FLEXIBLE CONN 35P P1.25
TGP047	AVR100 11P ST.WAFER
TGP048	AVR100 12P ST WAFER
TGP049	AVR100 3 PIN ST WAFER
TGP050	AVR100 WAFER (PCB/PCB) 16P P2.0
TGP051	AVR100 TR RN 1241-A
TGP052	AVR100 TR 2SC2878 (A,B) RL
TGP053	AVR100 IC M62447SP ELECTRIC
TGP054	AVR100 IC TC9164AN HV ANALOG SW
TGP055	AVR100 FUSE T5A/125V 5X20 MM
TGP056	AVR100 RMF 1/2W 8.2R 5% AL
TGP057	AVR100 3.15A TIME LAG 5X20
TGP058	AVR100 REPLAY 12VDC, 250VAC, 10A
TGP059	AVR100 TR DTC 123JSA ROHM
TGP060	AVR100 EI-35 TRANSFORMER GTP750
TGP061	AVR100 X'TAL 14.318MHZ +-20PPM
TGP062	AVR100 X'TAL 17.734MHZ +-20PPM

AVR100 Spares List

TGP063	AVR100 R 2SA933S HFE 120-560
TGP064	AVR100 IC LC74763-9012 OSD
TGP065	AVR100 IC BA7625 2X5CH
TGP066	AVR100 POWER SWITCH TV5
TGP067	AVR100 FRONT PANEL AL010C (SILVER)
TGP068	AVR100 FRONT PANEL AL010C (BLACK)
TGP069	AVR100 TOP COVER AL010C BLACK
TGP070	AVR100 BASS TREBLE KNOB
TGP071	AVR100 VOLUME KNOB
TGP072	AVR100 LENS
TGP073	AVR100 TUNER KNOBS
TGP074	AVR100 TONE KNOB
TGP075	AVR100 VOLUME KNOB HOLDER
TGP076	AVR100 FUNCTION KNOB
TGP077	AVR100 LED HOLDER
TGP078	AVR100 POWER KNOB
TGP079	AVR100 DC FAN 12V 80X80MM
TGP080	AVR100 X'FORMER I/P 120V/230V
TGP081	AVR100 SWITCH 110-220V DPDT
TGP082	AVR100 RMF 1/2W 2.2R 5% AT
TGP083	AVR100 RMF 5W 0.22R X2 10% RL
TGP084	AVR100 RCF 1/2W 2.7K 5% AT
TGP085	AVR100 RMF 1/4W 33R 1% AT
TGP086	AVR100 PHONE JACK
TGP087	AVR100 LED RED/GREEN (L-469HW)
TGP088	AVR100 RMF 1W 0.22R 5% AT
TGP089	AVR100 ROTARY ENCODER
TGP090	AVR100 TRANSFORMER BRACKET
TGP091	AVR100 TOP COVER AL010C SILVER
TGP092	AVR100 REAR PANEL
TGP093	AVR100 FOOT CAP
TGP094	AVR100 FOOT RUBBER
TGP095	AVR100 4 WAY SPEAKER TERMINAL
TGP096	AVR100 2 WAY SPEAKER TERMINAL
TGP097	TAPE GLASS CLOTH
TGP098	SHEILD SILICON STEEL 50 X 320MM X 0.3
TGP099	AVR100 MAIN AMP L/C/R TR2SC1740S
TGP100	AVR100 PCB ASSY DIGITAL AL010C
TGP101	AVR100 PCB ASSY AC3 BOARD (DECODER)
TGP102	AVR100 PCB ASSY POWER AMP L/R/C (LCR)
TGP103	AVR100 PCB ASSY POWER AMP SL/SR (REARS)
TGP104	AVR100 PCB ASSY AUDIO AL010C (XTRA AUDIO I/PS)
TGP105	AVR100 PCB ASSY KEYBOARD AL010C (DISPLAY)
TGP106	AVR100 PCB ASSY LED AL010C (SMALL POWER LIGHT)
TGP107	AVR100 PCB ASSY MAIN AL010C
TGP108	Blank spare part number
TGP109	AVR100 PCB ASSY MULTI AL010XC (PRE AMP)
TGP110	AVR100 PCB ASSYPOWER SUPPLY (MAINS IN)
TGP111	AVR100 PCB ASSYSECONDARY (TRANSFORMER OUTPUT)
TGP112	AVR100 PCB ASSY S-VIDEO AL010C (SUHS)
TGP113	AVR100 PCB ASSY TONE AL01XC (TONE CONTROL)
TGP114	AVR100 PCB ASSY TUNER AL01XC (TUNER BOARD)
TGP115	AVR100 PCB ASSY VIDEO AL01XC (VIDEO)
TGP116	AVR100 PCB ASSYVOLUME AL01XC (ROTARY ENCODER)
TGP117	AVR100 TONE CONTROL CABLE
TGP118	AVR100 OPTICAL INPUT BUNG
TGP119	Blank spare part number
TGP220	AVR100/200 FASCIA END CAP SILVER
TGP221	AVR100/200 FASCIA END CAP BLACK
TGP222	AVR100/200 TOP FOAM PACKING
TGP223	AVR100/200 BOTTOM FOAM PACKING
TGP224	AVR100 2200UF CAP 16V
TGP225	AVR100 47UF 50V CAPACITOR